

SGW-C 鋼片型 / 夾緊式 / 撓性聯軸器

DISK / CLAMP TYPE / FLEXIBLE COUPLING



材質 | Material

鋁合金 Aluminum alloy
緩衝材: 不銹鋼彈片
Buffer material: SUS disk

表面處理 | Surface Treatment

陽極處理 Anodizing standard white

特性 | Features

1. 扭力大
 2. 偏角誤差較佳
 3. 低慣性
 4. 零背隙
 5. 適用於工作母機、伺服馬達、高精密傳動
 6. 固定方式: 夾緊式
- High torque
 - High deflection
 - Low inertia
 - Zero backlash
 - Suitable for working machine, servomotor and high precision transmission mechanism.
 - Fixed mode: Clamp type

型號表示 | Product NO

SGW-50C- ϕ 20x ϕ 20

型號 / Type 孔徑 / Inside dia

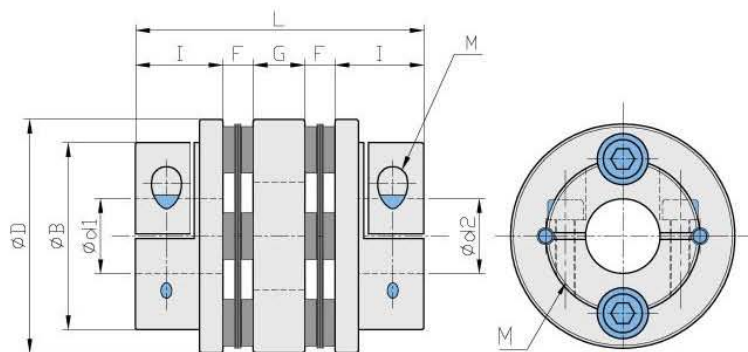

尺寸 | Dimension

單位 / Unit: mm

Catalog Number 型號	D	B	I	F	G	L	M	d1xd2 標準孔徑 (H7)		Mass** 重量 (g)
								Min	Max	
SGW-40C	40	28	15	4.5	9	48	3-M4	8	16	100
SGW-45C	45	33	15	4.5	9	48	4-M4	10	18	120
SGW-50C	50	40	20	6.5	11	64	4-M5	10	20	230
SGW-57C	57	42	20	6.5	11	64	4-M5	10	22	248
SGW-65C	65	50	24	7.0	14	76	4-M6	12	28	540

性能 | Specifications

單位 / Unit: mm

Catalog Number 型號	Rated Torque 一般扭力 (N.m)	Max. Torque 最大扭力 (N.m)	Max Rotational Frequency 最高回轉速 (Rpm/min)	Moment* of Inertia 慣性 (Kg · m ²)	Errors of Eccentricity 容許偏心 (mm)	Errors of Shaft End-Play 容許軸向位差 (mm)	Errors of Angularity 容許偏角 ($^{\circ}$)
SGW-40C	6	12	10000	15.3x10 ⁻⁶	0.2	±0.6	1.5
SGW-45C	9	18	10000	28.2x10 ⁻⁶	0.2	±0.6	1.5
SGW-50C	17	34	10000	53.6x10 ⁻⁶	0.2	±0.8	1.5
SGW-57C	25	50	10000	87.1x10 ⁻⁶	0.25	±0.8	1.5
SGW-65C	55	110	10000	225.9x10 ⁻⁶	0.3	±0.9	1.5