

# SGS-C 鋼片型 / 夾緊式 / 短型撓性聯軸器

DISK / CLAMP TYPE / SHORTER OF FLEXIBLE COUPLING



### 材質 | Material

鋁合金 Aluminum alloy  
緩衝材: 不銹鋼彈片  
Buffer material: SUS disk

### 表面處理 | Surface Treatment

陽極處理 Anodizing standard white

### 特性 | Features

- |  |  |
|--|--|
| <ol style="list-style-type: none"> <li>1. 高剛性</li> <li>2. 扭力大</li> <li>3. 低慣性</li> <li>4. 零背隙</li> <li>5. 適用於工作母機、伺服馬達、<br/>高精密傳動</li> <li>6. 固定方式: 夾緊式</li> </ol> | <ul style="list-style-type: none"> <li>• High rigid</li> <li>• High torque</li> <li>• Low inertia</li> <li>• Zero backlash</li> <li>• Suitable for working machine、<br/>servomotor and high precision<br/>transmission mechanism.</li> <li>• Fixed mode: Clamp type</li> </ul> |
|--|--|

### 型號表示 | Product NO

**SGS-27C- $\phi 6 \times \phi 6$**

型號 / Type      孔徑 / Inside dia

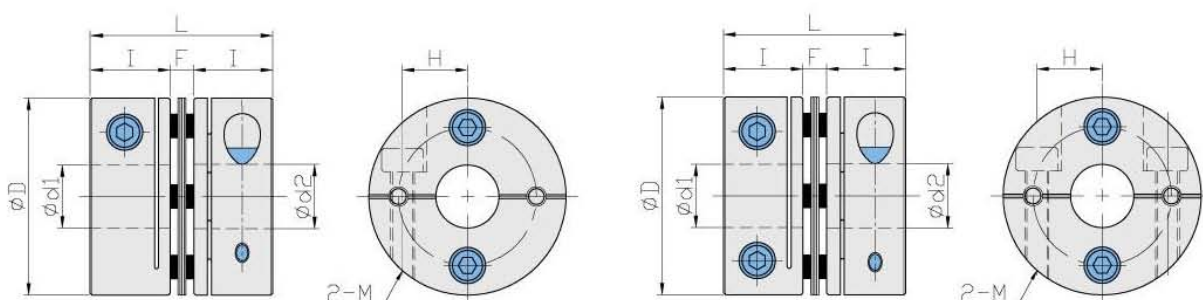

外徑  $\phi 27 \sim \phi 34$

外徑  $\phi 40 \sim \phi 65$

### 尺寸 | Dimension

單位 / Unit:mm

Catalog Number 型號	D	I	F	L	H	M	d1xd2 標準孔徑 (H7)		Mass** 重量 (g)
							Min	Max	
SGS-27C	27	10.5	2.5	23.5	9.0	M3	5	10	30
SGS-34C	34	12.0	3.0	27.0	12.0	M3	6	14	48
SGS-40C	40	15.0	4.5	34.5	14.0	M4	8	16	93
SGS-45C	45	15.0	5.0	34.5	16.0	M4	10	19	110
SGS-50C	50	20.0	6.0	46.0	18.0	M5	10	22	215
SGS-57C	57	20.0	6.0	46.0	21.0	M5	12	25	240
SGS-65C	65	24.0	7.0	55.0	25.0	M6	12	28	445

### 性能 | Specifications

單位 / Unit:mm

Catalog Number 型號	Rated Torque 一般扭力 (N.m)	Max. Torque 最大扭力 (N.m)	Max Rotational Frequency 最高回轉速 (Rpm/min)	Moment* of Inertia 慣性 (Kg · m <sup>2</sup> )	Errors of Eccentricity 容許偏心 (mm)	Errors of Shaft End-Play 容許軸向位差 (mm)	Errors of Angularity 容許偏角 (°)
SGS-27C	1.5	3	10000	2.5x10 <sup>-6</sup>	0.02	± 0.15	1.0
SGS-34C	6	12	10000	8.2x10 <sup>-6</sup>	0.02	± 0.20	1.0
SGS-40C	7	14	10000	19.0x10 <sup>-6</sup>	0.02	± 0.25	1.0
SGS-45C	10	20	10000	29.7x10 <sup>-6</sup>	0.02	± 0.30	1.0
SGS-50C	17	34	10000	75.0x10 <sup>-6</sup>	0.02	± 0.30	1.0
SGS-57C	25	50	10000	100.0x10 <sup>-6</sup>	0.02	± 0.40	1.0
SGS-65C	25	110	10000	250.0x10 <sup>-6</sup>	0.02	± 0.40	1.0